

H112/03

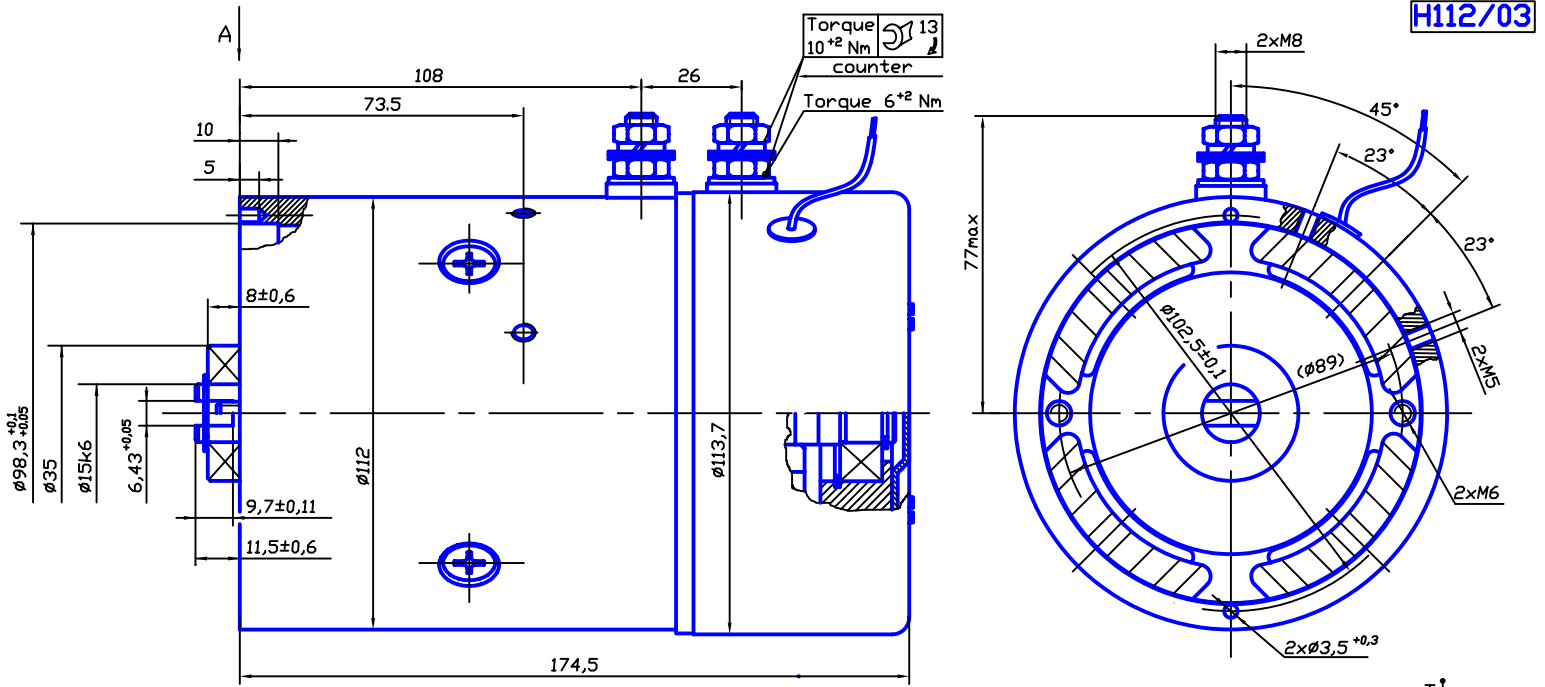

Note: The motors are with a fixed rear bearing

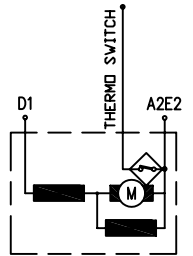
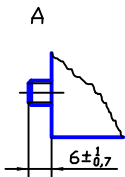

CODE	V	kW	RPM	Rate	Rot	IP	Curve
------	---	----	-----	------	-----	----	-------

MH112 1.5/27 1203	12	1,5	2700	S2-4min	CWDE	IP44	fig.1
MH112 2.0/23 1203	12	2,0	2300	S2-1,5min	CWDE	IP44	fig.1
MH112 1.5/27 2403	24	1,5	2700	S2-5min	CWDE	IP44	fig.2
MH112 2.0/23 2403	24	2,0	2300	S2-2min	CWDE	IP44	fig.2

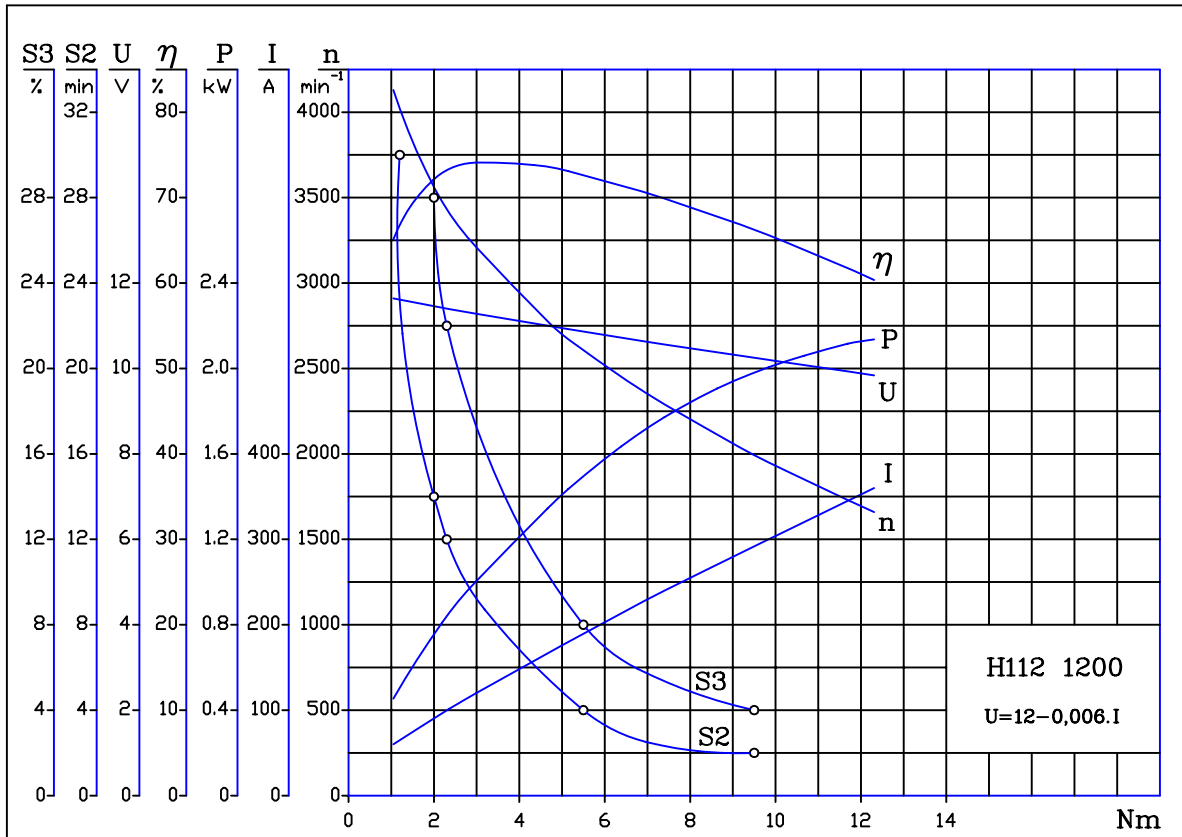

fig.1

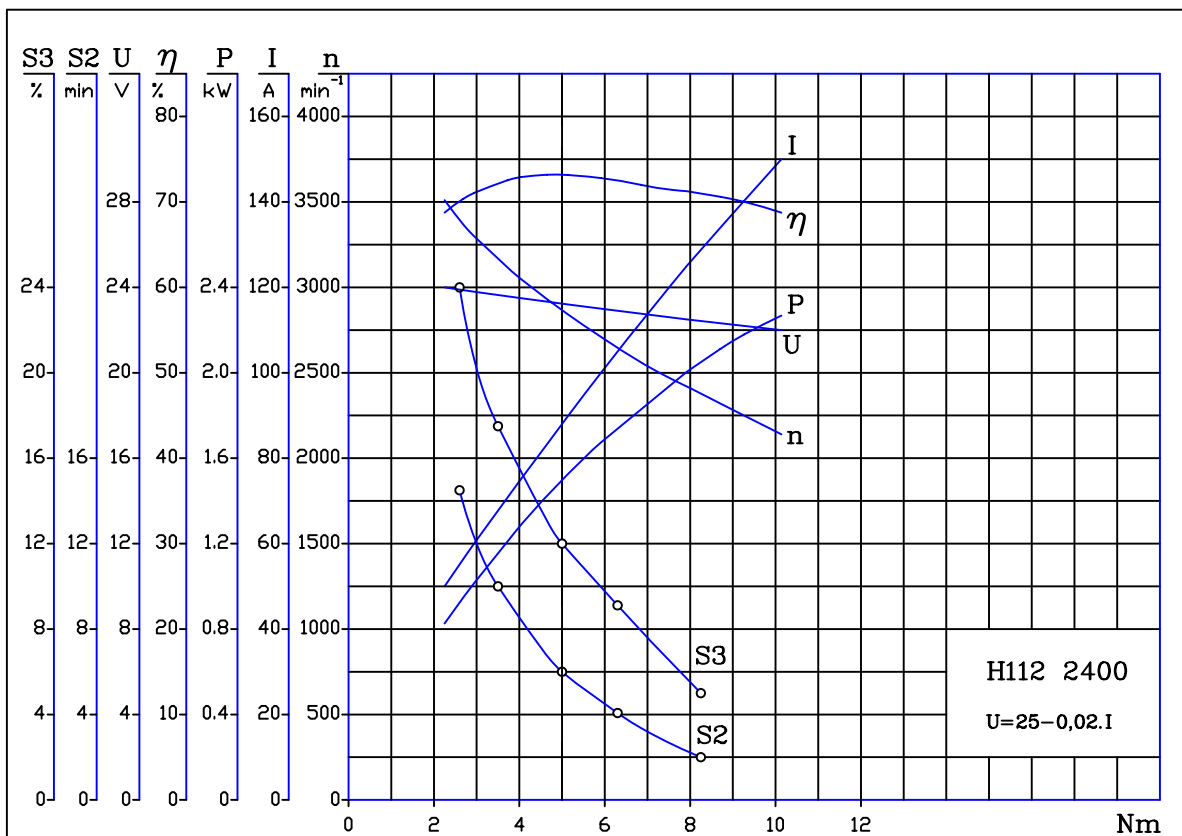

fig.2