

**H125/00**

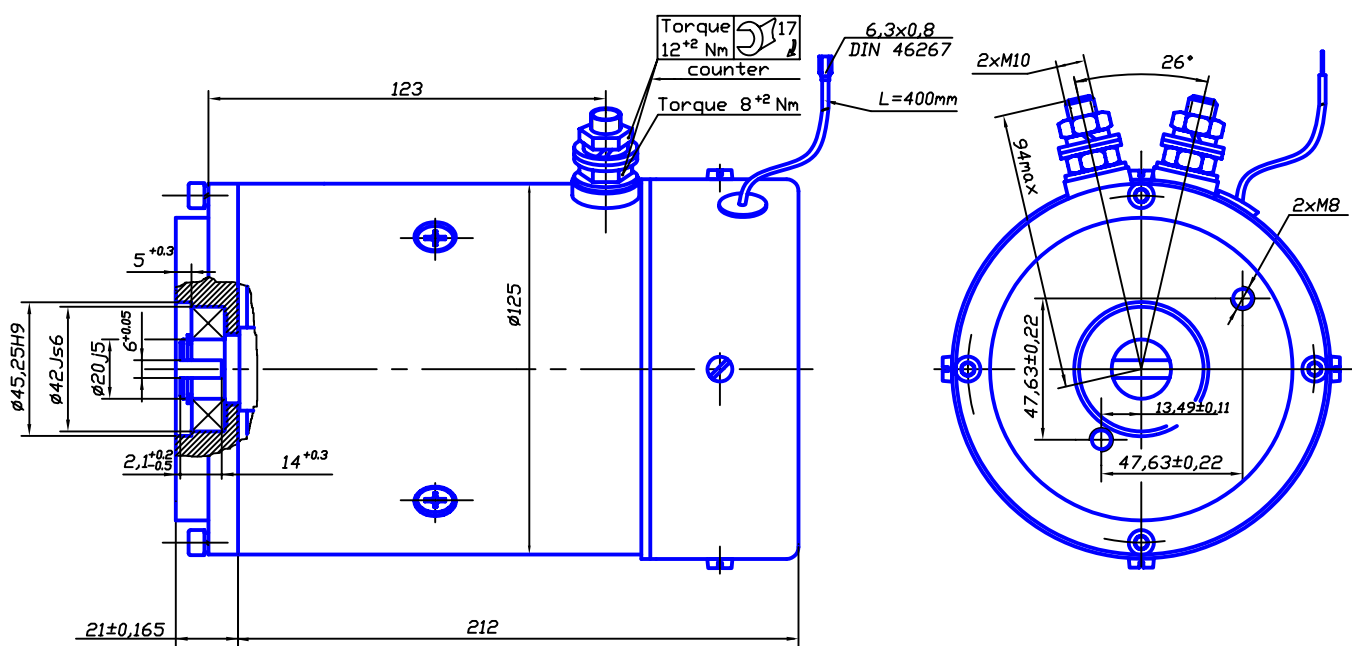

NOTE: The front side bearing fixing is ensured after the mounting of the pump. The other bearing is free.

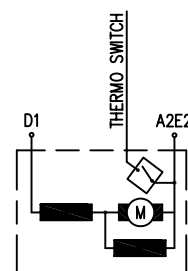

CODE	V	kW	RPM	Rate	Rot	IP	Curve
MH125 3.0/35 1200	12	3.0	3500	S2-3,5min	CWDE	IP44	fig.1
MH125 3.0/35 2400	24	3,0	3500	S2-4,5min	CWDE	IP44	fig.2

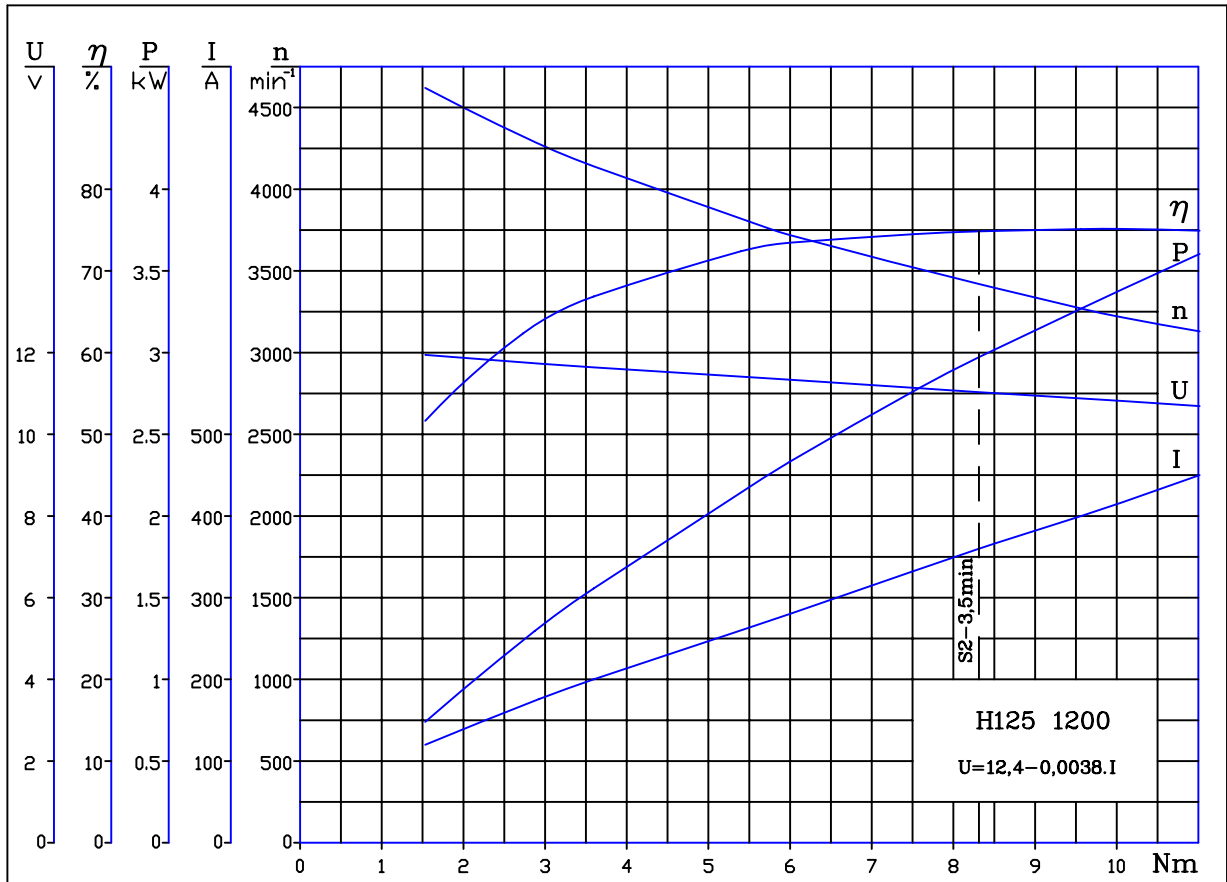

fig.1

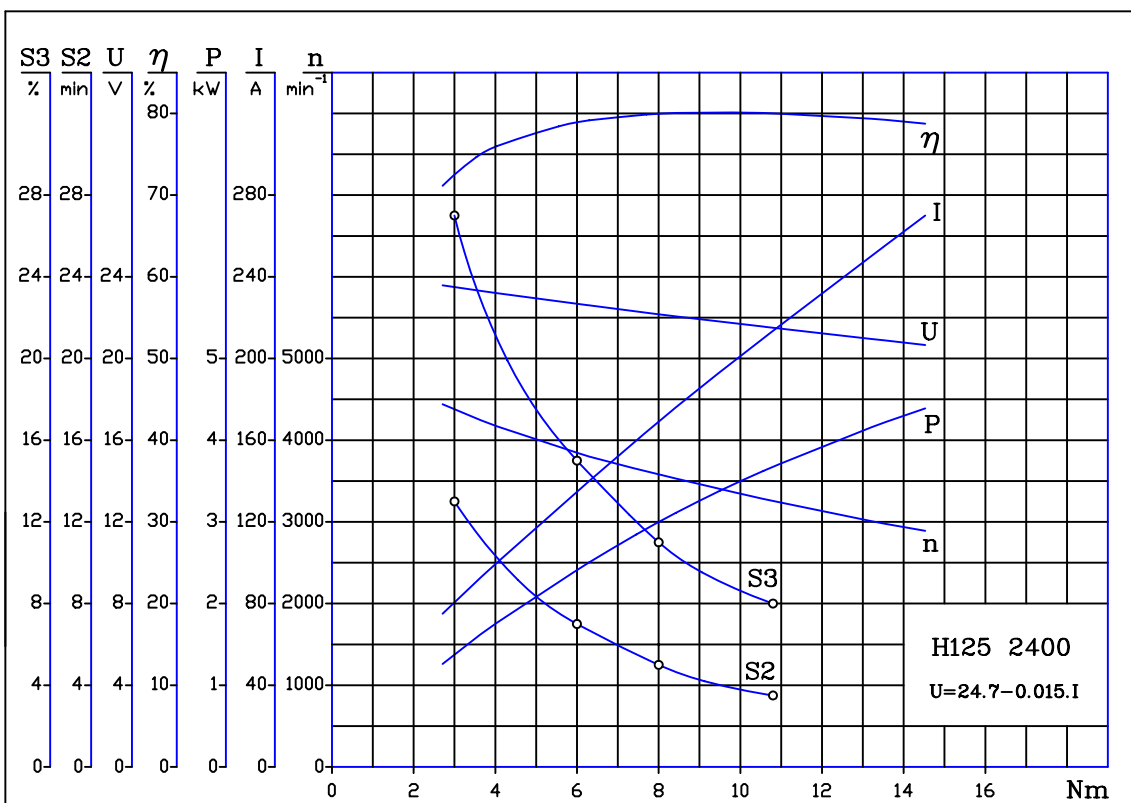

fig.2