

H125/01

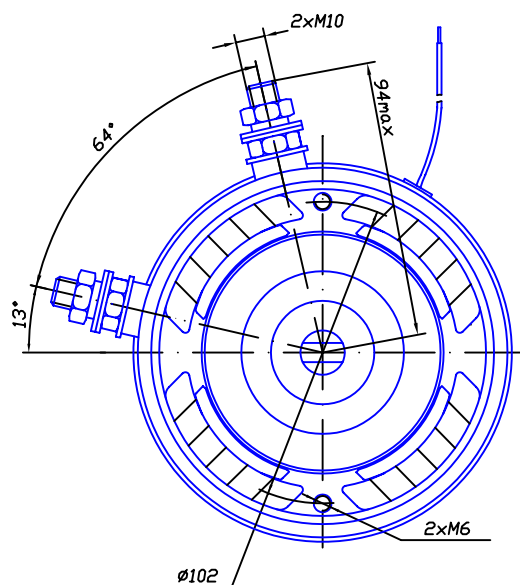

Note: The motors are with a fixed rear bearing

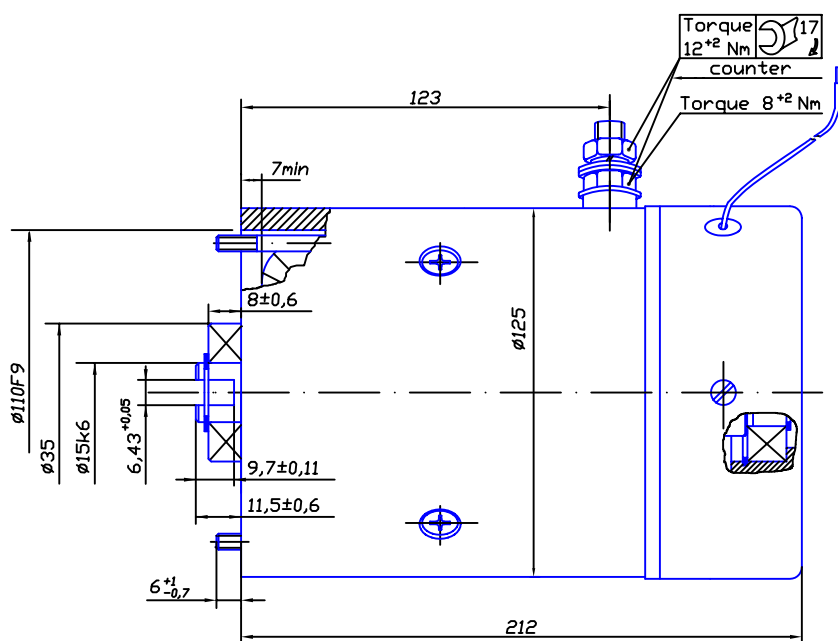
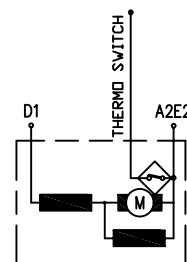

CODE	V	kW	RPM	Rate	Rot	IP	Curve
MH125 3.0/35 1201	12	3.0	3500	S2-3,5min	CWDE	IP44	fig.1
MH125 3.0/35 2401	24	3,0	3500	S2-4,5min	CWDE	IP44	fig.2

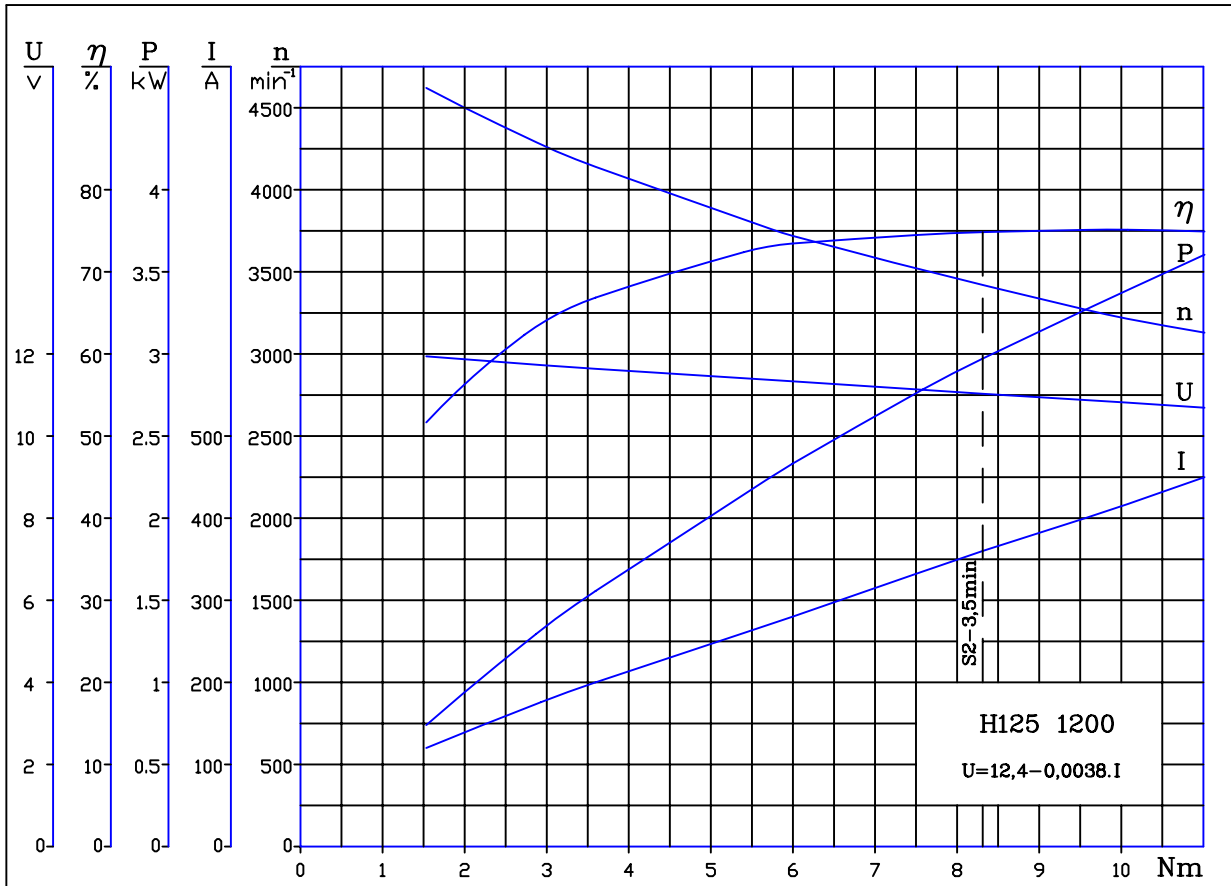

fig.1

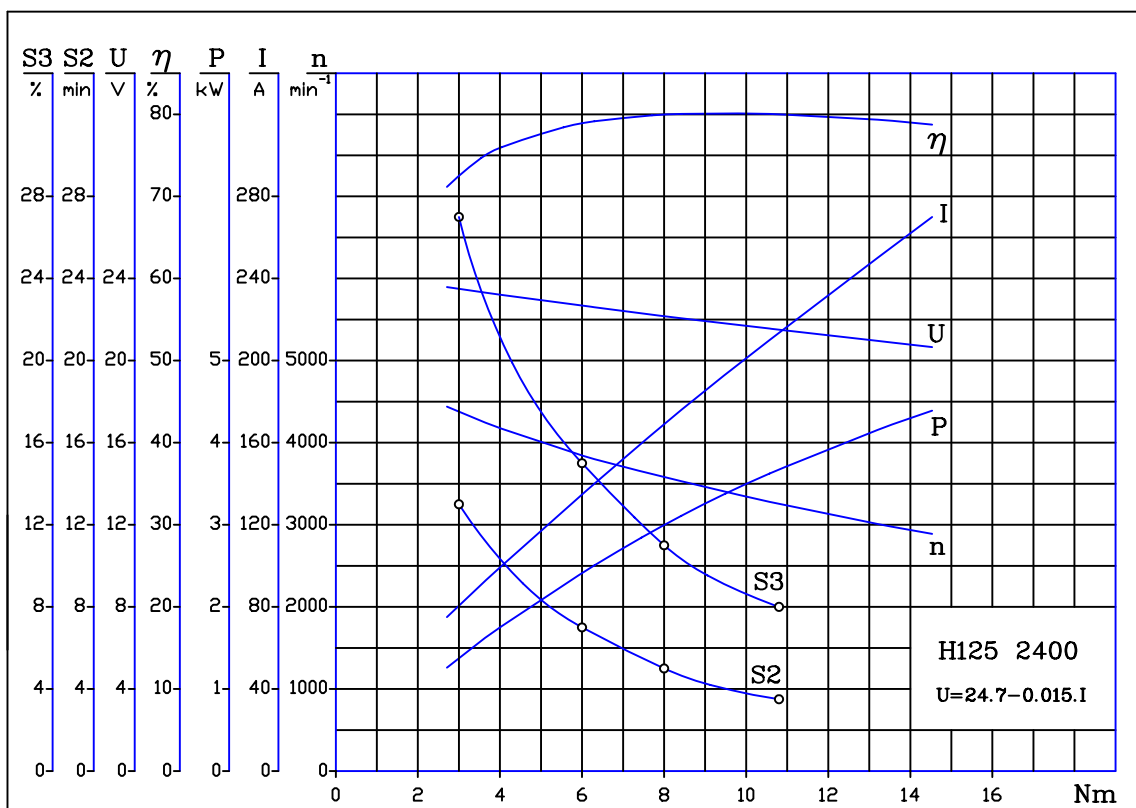

fig.2